

RYA SCOTLAND YOUTH AND JUNIOR CHAMPIONSHIPS

Dalgety Bay Sailing Club

21st – 22nd SEPTEMBER 2019

CHAMPIONSHIP FLEET SAILING INSTRUCTIONS

The Organizing Authority is the Royal Yachting Association Scotland (RYAS)
in conjunction with Dalgety Bay Sailing Club (DBSC)

The notation [DP] in a rule in the Sailing Instructions means that the penalty for a breach of the rule may, at the discretion of the protest committee, be less than disqualification.

1 RULES

- 1.1 The Regatta will be governed by the rules as defined in the Racing Rules of Sailing (RRS).
(a) RRS Appendix P, Special Procedures for Rule 42 on the Bravo Course

2 NOTICES TO COMPETITORS

- 2.1 Notices to competitors will be posted on the official Regatta Notice Board located on the ground floor in the club house of DBSC
2.2 The Race Office will be situated on the ground floor in the DBSC Training room.

3 CHANGES IN SAILING INSTRUCTIONS

Any change(s) to the sailing instructions will be posted not less than one hour before the first start on the day it will take effect, except that any change to the schedule of races will be posted by 19:00 on the day before it will take effect.



4 SIGNALS MADE ASHORE







- 4.1 Signals ashore will be displayed from the flagpole located outside DBSC Clubhouse.
4.2 When flag AP is displayed ashore, '1 minute' is replaced with 'not less than 30 minutes' in the race signal AP. This changes RRS Race Signal AP.
4.3 Boats shall not launch until Flag D is displayed with one sound signal. [DP]
4.4 Flag L with one sound means "A notice to competitors has been posted on the official notice board".



5 SCHEDULE OF RACES & CLASS FLAGS

- 5.1 The Competitor's briefing will take place at 10:30hrs on Saturday outside the race box at the front of Dalgety Bay Sailing Club.
5.2 The event will comprise a maximum of 6 races for the dinghy classes (except 29ers) and a maximum of 8 races for the Windsurfer/29er fleet. Any class may sail up to five races on either day at the discretion of the race committee.
5.3 Following racing on the Sunday there will be a final race which will not be included in the overall results for each fleet. Race format will be briefed on the Sunday morning.

Day	Race Area	Fleet	Class Flag	Time of First Signal (Not Before)	Number of Races
Saturday 21 SEP 2019	Alpha	Topper	T 	11:55	Up to 5
		Laser Radial & 4.7	G 		

		Optimist	O 		
	Bravo	Feva	F 	11:55	Up to 5
		29er	E 		
	Bravo	420	J 	11:55	Up to 5
		Windsurfer 6.8, 7.8	K 		
		Windsurfer 4.5, 5.8	Q 		

Day	Race Area	Fleet	Class Flag	Time of First Signal (Not Before)	Number of Races
Sunday 22 SEP 2019	Alpha	Topper	T	10:25	Up to 5
		Laser Radial & 4.7	G		
		Optimist	O		
	Bravo	Feva	F	10:25	Up to 5
		29er	E		
		420	J		
		Windsurfer 6.8, 7.8, Windsurfer 4.5, 5.8	K Q		

5.4 To alert boats that a race or sequence of races will begin soon, an orange flag will be displayed (with one sound) at least 5 minutes before the first warning signal of a series of starts is displayed. No warning signal will be made after 14:30 on Sunday.

6 RACING AREAS

Both Alpha and Bravo race areas will be located on the Firth of Forth as noted in Appendix 3.

7 COURSES

7.1 The diagrams in Appendices 1, 2 and 3 show the courses for each race and the race area, including the order in which marks are to be passed and the side on which each mark is to be left. They do not accurately indicate the angle or distance between legs.

7.2 The Committee Vessel will display the course to be sailed using a black letter or number on a white background.

7.3 A gate may be replaced by a single mark to be left to port.

8 MARKS

8.1 **ALPHA RACE AREA:** Marks 1, 2, 3s, 3p, 4s and 4p will be yellow inflatable race marks. Marks 1a and 2a, will be blue inflatable race marks. The Start mark will be an orange inflatable race mark. The Finish mark will be a yellow inflatable pillar mark.

8.2 **BRAVO RACE AREA:** Marks 1, 2s and 2p will be pink inflatable race marks (with a black band). Mark 1a will be a blue inflatable race mark. The Start mark will be an orange inflatable race mark. The Finish mark will be a yellow inflatable pillar mark.

9 THE START

9.1 The starting line will be between the mast or staff displaying an orange flag on the Committee Vessel and a orange inflatable race mark.

9.2 Boats whose preparatory signal has not been made shall avoid the starting area.

9.3 A boat starting later than 4 minutes after her starting signal will be scored Did Not Start. This changes RRS Rules A4 and A5. [DP]

10 CHANGE OF COURSE AFTER THE START

To change the next leg of a course, the race committee will move the original mark (or the finishing line) to a new position using the procedure stated in RRS Rule 33

C 

11 SHORTEN COURSE

11.1 The race committee may shorten the course at any mark using the procedure stated in RRS Rule 32.2.



11.2 In addition to the procedure for shortening course in RRS Rule 32.2, the race committee may also award a finishing score to a boat that is still racing by displaying to her from a committee vessel (which may be in motion) flag W with one sound signal. A boat so notified is no longer required to sail the course, shall stop racing and shall return to the starting area, or return ashore if there is no more racing. A finishing score under this sailing instruction will be the score she would have received had she sailed the course and finished within any time limit, without gaining or losing any place. The decision by the race committee to use this procedure or not to use it shall not be grounds for requesting redress. This changes RRS Rules 28.1, 32.2, and 60.1(b).

12 FINISHING LINE

The finishing line will be between the mast or staff displaying a blue flag on the committee vessel and yellow inflatable pillar mark.

13 TARGET TIMES AND TIME LIMITS

The target time for classes on Course Alpha will be 45 minutes. The target time for classes on Course Bravo will be 30 minutes. The time limit for each class will be 75 minutes after the start of their race. Boats failing to finish within 20 minutes after the first boat in their class sails the course and finishes will be scored Did Not Finish. This changes RRS Rule 35 and A4.

14 PROTESTS AND REQUESTS FOR REDRESS.

14.1 Protest forms are available from the Race Office in DBSC. Protests shall be delivered there within the protest time limit.

14.2 The protest time limit is 45 minutes after the last boat has finished the last race of the day. The actual Time Limit will be posted on the Notice Board.

14.3 Notices will be posted within 30 minutes of the expiry of the protest time limit to inform competitors of hearings in which they are parties or named as witnesses. Hearings will take place in the protest hearing room located in DBSC. Parties to each protest are requested to remain in the vicinity.

14.4 Notices of protests by the race committee will be posted to inform boats under RRS Rule 61.1(b).

14.5 Protests will be heard as soon as possible, in approximately the order of receipt. It is the responsibility of the Protestor, Protestee and witnesses to make themselves available for the hearing.

14.6 The Post-Race Penalty and the Advisory Hearing and RYA Arbitration procedures of the RYA Rules Disputes procedures shall apply. The outcome of an RYA Arbitration can be referred to a protest committee, but an arbitration cannot be reopened or appealed. See the Official Notice Board for details.

14.7 On the last day of racing a request for reopening a hearing shall be delivered:

- (a) within the protest time limit if the party requesting reopening was informed of the decision on the previous day;
- (b) no later than 30 minutes after the party requesting reopening was informed of the decision on that day.

This changes RRS Rule 66.

15 SCORING

15.1 One race is required to be completed to constitute a series.

(a) When fewer than 4 races have been completed, a boat's series score will be the total of her race scores.

(b) When 4 to 6 races have been completed, a boat's series score will be the total of her race scores excluding her worst score.

(c) When 7 or more races have been completed, a boat's series score will be the total of her race scores excluding her two worst scores.

16 SAFETY REGULATIONS [DP]

16.1 All competitors shall wear a personal flotation device at all times when afloat, except briefly when changing or adjusting clothing or personal equipment. Wet suits and dry suits are not considered personal flotation devices. This changes RRS Rule 40.

16.2 **CHECK-OUT AND CHECK-IN:** A tally system will be used during the regatta; the tallies will be numbered rubber wristbands which should be worn on each competitor's wrist. Individual tally numbers will be allocated at registration.

To check-out tallies shall be collected from the tally board which will normally be positioned at the top of the launch ramp prior to going afloat. To check-in the tally should be returned to the tally board immediately on returning to shore after racing, but no later than the protest time limit.

Competitors that fail to tally correctly may be subject to protest by the Race Committee. Any points penalty shall be applied to the first completed race on the day the infringement took place. This changes RRS Rule 63.1.

16.3 Penalties for breaches of RRS Rule 41 (Outside Help) will be at the discretion of the protest committee. Any outside help shall be reported to the Race Office before the protest time limit on the day concerned.

17 TRASH DISPOSAL [DP]

Trash may be placed on any official boat or support boat. The penalty for breaking Rule 55, Trash Disposal, is at the discretion of the protest committee and may be less than disqualification.

18 RIGHTS TO USE NAMES AND LIKENESSES

18.1 Boats may be required to carry tracking equipment, cameras, sound equipment, or positioning equipment. A boat shall not protest another boat nor seek redress based on a claim involving this equipment. This changes RRS Rules 60.1 and 62.1.

19 SUBSTITUTION OF COMPETITORS OR EQUIPMENT.

Substitution of competitors or equipment shall not be permitted without the written approval of the race committee.

20 CAMERAS AND ELECTRONIC RECORDING EQUIPMENT [DP]

Boats may be required to carry tracking equipment, cameras, sound equipment, or positioning equipment. A boat shall not protest another boat or seek redress based on a claim involving this equipment. This changes RRS 60.1 and 62.1.

21 PRIZES

The organising authority shall award prizes to the first three boats in each class. Fewer prizes may be awarded, at the discretion of the organising authority, depending on the number of entries in each class.

22 RISK STATEMENT

22.1 Rule 4 of the Racing Rules of Sailing states: "The responsibility for a boat's decision to participate in a race or to continue racing is hers alone."

22.2 Sailing is by its nature an unpredictable sport and therefore inherently involves an element of risk. By taking part in the event, each competitor agrees and acknowledges that:

- (a) They are aware of the inherent element of risk involved in the sport and accept responsibility for the exposure of themselves, their crew and their boat to such inherent risk whilst taking part in the event;
- (b) They are responsible for the safety of themselves, their crew, their boat and their other property whether afloat or ashore;
- (c) They accept responsibility for any injury, damage or loss to the extent caused by their own actions or omissions;
- (d) Their boat is in good order, equipped to sail in the event and they are fit to participate;
- (e) The provision of a race management team, patrol boats and other officials and volunteers by the event organiser does not relieve them of their own responsibilities;
- (f) The provision of patrol boat cover is limited to such assistance, particularly in extreme weather conditions, as can be practically provided in the circumstances.
- (g) it is their responsibility to familiarize themselves with any risks specific to the venue or this event which will be drawn to their attention in any of the rules and/or information produced for the event and venue.

23 INSURANCE

Each participating boat shall be insured with valid third-party liability insurance with a minimum cover of £3,000,000 per event.

Appendix 1 – Alpha Race Area Courses

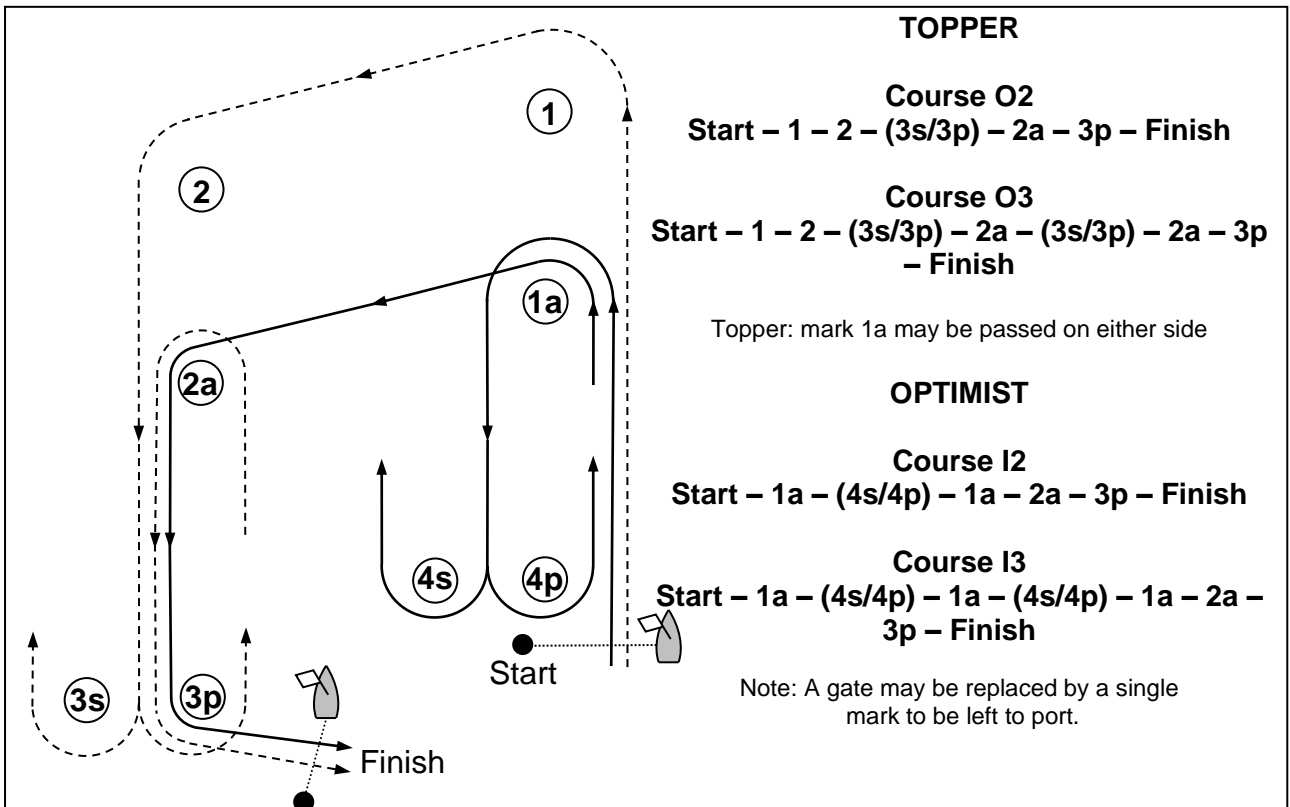
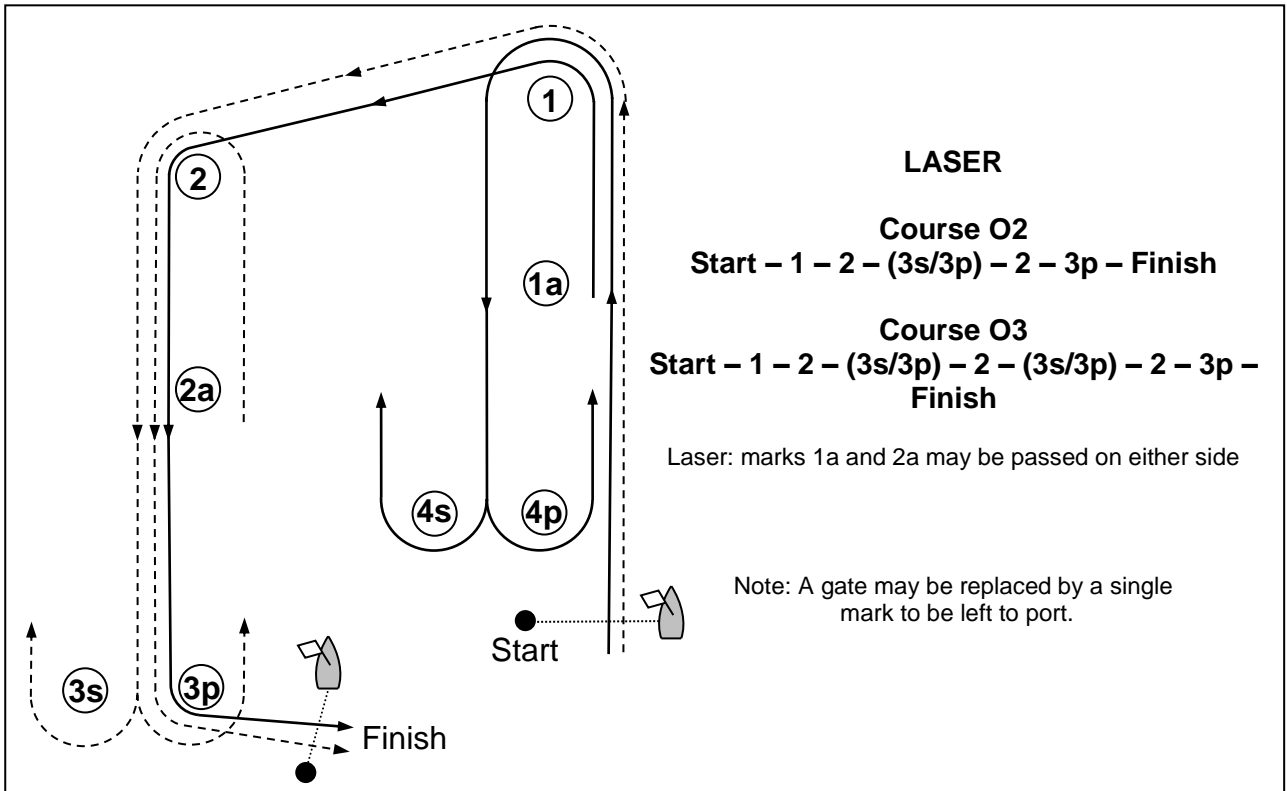

Appendix 2 – Bravo Race Area Courses

WINDSURFER 6.8, 7.8, RS:X, 29er, 420, RS Feva XL

Course L1:
Start – 1 – 2p – Finish

Course L2:
Start – 1 – (2s/2p) – 1 – 2p – Finish

Course L3:
Start – 1 – (2s/2p) – 1 – (2s/2p) – 1 – 2p – Finish

Note: A gate may be replaced by a single mark to be left to port.

WINDSURFER 4.5, 5.8,

Course L1:
Start – 1a – 2p – Finish

Course L2:
Start – 1a – (2s/2p) – 1a – 2p – Finish

Course L3:
Start – 1a – (2s/2p) – 1a – (2s/2p) – 1a – 2p – Finish

Note: A gate may be replaced by a single mark to be left to port.

Appendix 3 –Racing Areas

